

## TECHNICAL DATA SHEET

### Double chamber blood administration kit

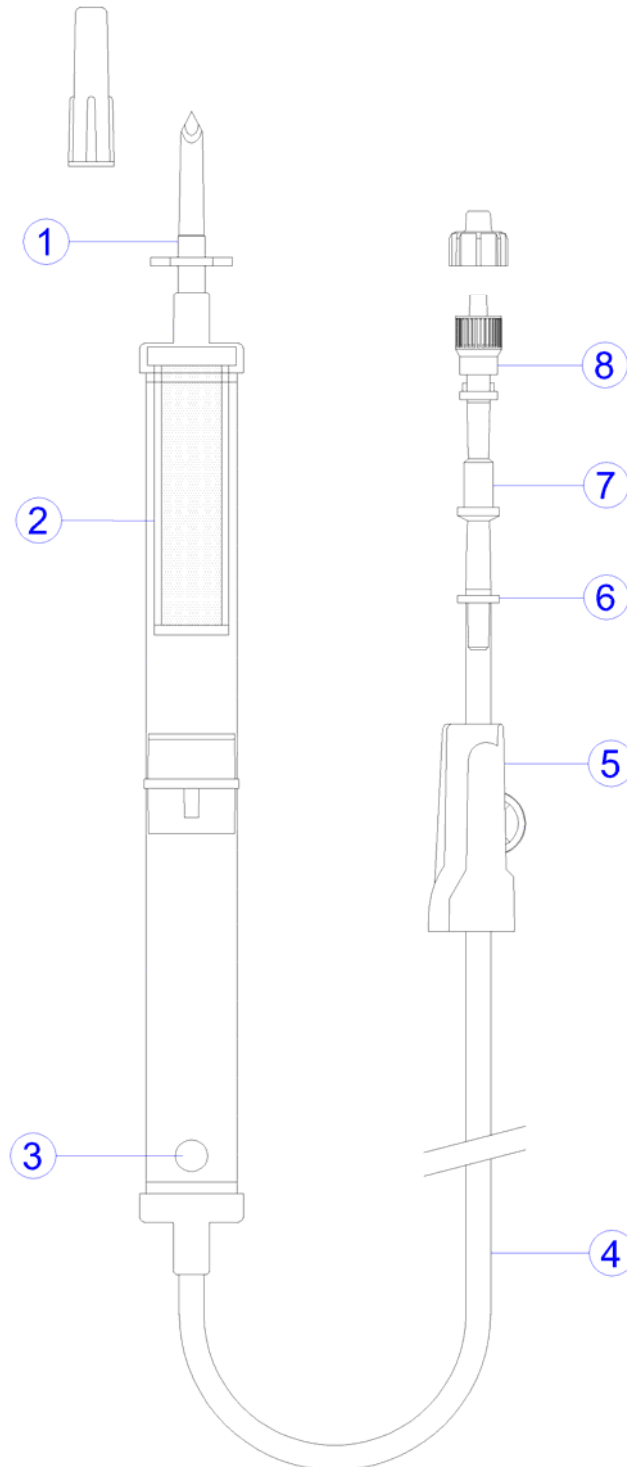

CODE	DISTRIBUTOR CODE	BOX pcs.
MSI/022A	UNAA100	20



HMC PREMEDICAL SPA

Via Tonino Morandi, 16 - 41037 MIRANDOLA (MO) ITALY Tel. 0535 22704 - Fax. 0535 609546 info@hmcgroup.it



#### ● PRODUCT COMPOSITION:

1. Spike in white **MBS** with finger guard and protective cap in blue **Polyethylene**.
2. Double drip chamber in **PVC**, O.D. 18 mm and length 200 mm, with 200 µm blood filter in **Nylon**.
3. Floating level indicator ball in white **Polypropilene**.
4. Tube in **PVC**, I.D. 4mm / O.D. 5,5 mm. with a length of 155 cm.
5. Roller clamp in **ABS**.
6. Rigid connector in **PVC**.
7. Infusion connector in **latex-free Polyisoprene**.
8. Rotating M.L.L. in **PVC-ABS** with vented cap in **Polyethylene**.

#### ● INTENDED USE:

Device for blood and hemoderivatives administration.

#### ● PACKAGING:

Single packaged in medical paper/PP-PE blister; boxes of 20 pieces.

This product has a customized labelling which states the distributor information and alternative product code (UNAA100).

#### ● PRODUCTION PROCESS:

The device is manufactured in accordance to HMC Premedical S.p.A. Quality System and in compliance with EN ISO 13485 requirements.

#### ● PRODUCT CONTROL:

During all production phases as per internal procedures and in accordance to ISO 2859-1 sampling plan.

#### ● CLASSIFICATION:

Class **IIA** sterile.

#### ● STERILIZATION:

Product sterilized with ETO (Ethylene Oxide) according to a treatment cycle validated in compliance with current standards.

Shelf life of 5 years from sterilization date.

Non re-sterilizable and for single-use only.

#### ● STORAGE:

Standard storage procedures and conditions.

#### ● DISPOSAL:

Product disposal must be carried out in accordance with regulations for hospital waste disposal.

#### ● WARNINGS:

The device must be used exclusively by healthcare professionals.

#### ● REGISTRATION TO ITALIAN M.D. REPERTOIRE:

CND: **A03010102**

RDM: **326147**

REV. Rev.	MODIFICHE Changes	DATA Date	EMESSO Issued	VERIFICATO e APPROVATO Verified and Approved
00	First issue – English language	16/05/2019	E. Benassi	E. Benassi